

The Ramsey Model 90.151 Low Capacity Weighbelt Feeder offers accurate weighfeeding of light materials at low feed rates. Its unique design and construction features provide a consistent flow of materials, offer increased sensitivity for more accurate weighing of the lightest materials, and permit quick and easy cleaning and maintenance. These features work together to augment the performance of your process and improve your bottom line.

Ramsey Model 90.151 Low Capacity Weighbelt Feeder

Accurate conveyor weighing of bulk materials



Ramsey Model 90.151 Low Capacity Weighbelt Feeder shown without side cover

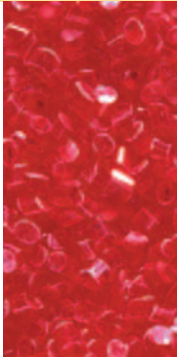

Cantilevered frame and quick release take-up for easy belt removal

Precise feeding of process materials is often critical to maintaining product quality. A feeder that weighs accurately and reliably can reduce material waste, help maintain blend consistency and increase profits.

Thermo Electron Corporation has well over 30 years of experience designing and manufacturing weighbelt feeders. Every feeder is designed to meet the specific needs of the application. We work closely with our customers to ensure that each

system meets their expectations for performance and dependability.

The Ramsey Model 90.151 Low Capacity Weighbelt Feeder from Thermo is designed for weighfeeding applications with low feed rates and light belt loading requirements. It accommodates flow rates as low as 54 (120 lb) per hour up to 22,680 kg (50,000 lb) per hour, and belt loadings of 3 kg/m (2 lb/ft) to 30 kg/m (20 lb/ft).

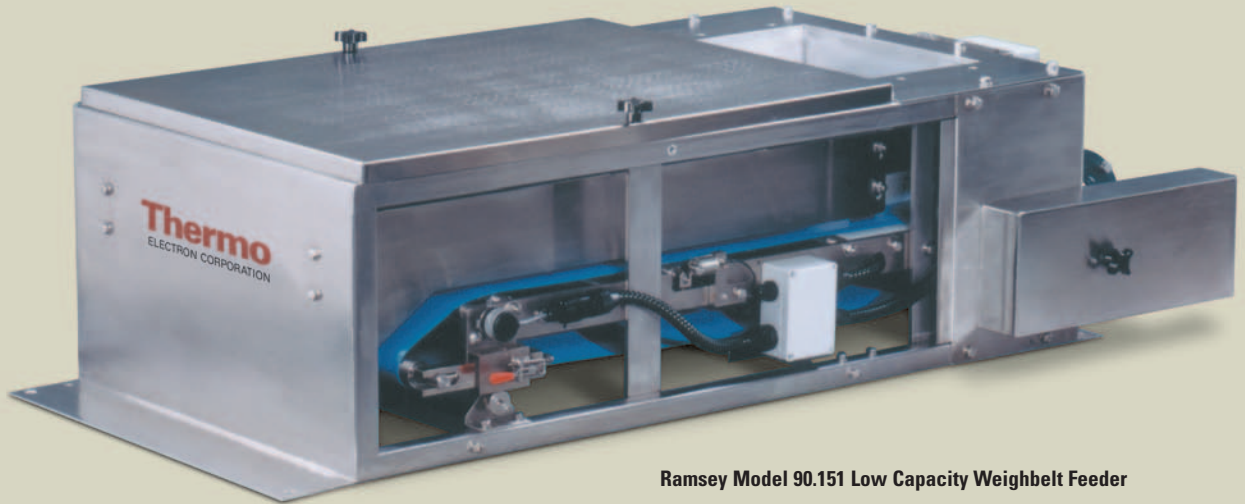

Ramsey Model 90.151 Low Capacity Weighbelt Feeder

Theory of Operation

Material is fed onto the feeder through an inlet feed section equipped with a manually adjustable vertical slide gate to control material height. The scale carriage/weighbridge assembly measures the gravitational force of the material and converts this force measurement into an electrical output signal proportional to belt loading.

A digital speed sensor continuously monitors the belt speed. The microprocessor-based electronics integrate the two signals to produce and display a true rate and a total weight fed. The electronics also provide an output signal for control and monitoring purposes.

For more information about the Ramsey Micro-Tech series of electronic integrators, please refer to catalog PI.8011.0703.

Features and Benefits

The Ramsey Model 90.151 Low Capacity Weighbelt Feeder, with its innovative design and unique features, was developed to meet the high standards and greater accuracy demands of today's food, chemical and process industries.

- *Unique Head Pulley Configuration:* The chisel-shaped pulley configuration on the discharge end of the belt provides an even, consistent flow of difficult process materials off of the belt.
- *Tail Drive Arrangement:* This reduces carry-side belt tensions to provide greater sensitivity for more accurate weighing of the lightest materials.
- *Cantilever Design:* This feature permits quick and easy belt removal for cleaning and maintenance.
- *Dual Load Cell Scale:* Dual load cells enable a higher degree of response to material weight variations.
- *Stainless Steel Construction:* Stainless steel provides improved corrosion resistance and washdown capabilities.

Ramsey Model 90.151 Low Capacity Weighbelt Feeder — Schematic Diagram

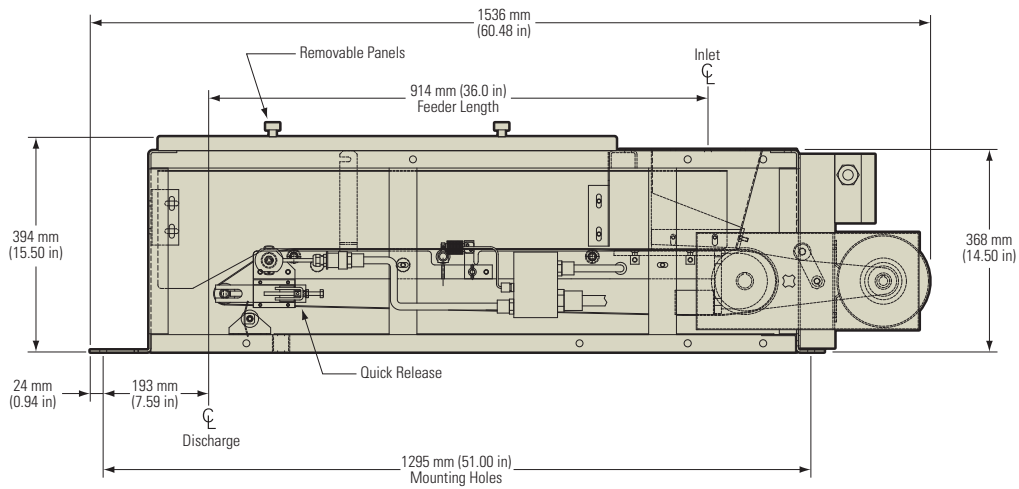

SIDE VIEW

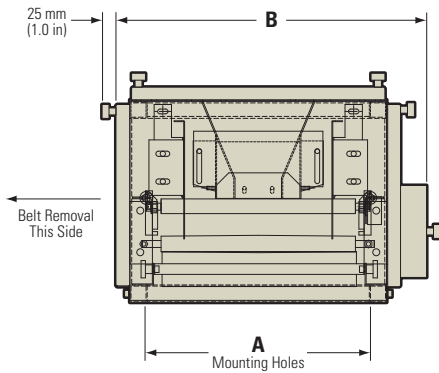

END VIEW

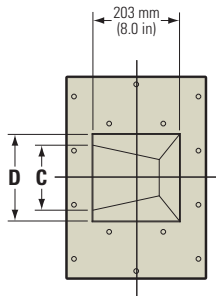

INLET FLANGE DETAIL

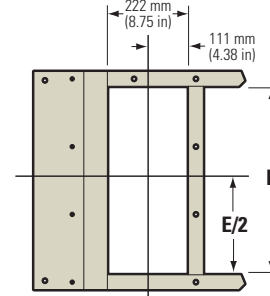

DISCHARGE FLANGE DETAIL

Ramsey Model 90.151 Low Capacity Weighbelt Feeder — Variable Dimensions

BELT WIDTH	A	B	LENGTH (mm)		
			C	D	E
305 mm	432	568	152	203	406
457 mm	584	721	305	356	559
610 mm	737	873	457	508	711

BELT WIDTH	A	B	LENGTH (in)		
			C	D	E
12 in	17.00	22.38	6.00	8.00	16.00
18 in	23.00	28.38	12.00	14.00	22.00
24 in	29.00	34.38	18.00	20.00	28.00

Ramsey Model 90.151 Low Capacity Weighbelt Feeder

Specification

General Specifications

Accuracy	± 0.25% to 1% of set rate at 2 sigma, based on approved applications and test requirements
Belt Width	305 mm (12 in), 457 mm (18 in), 610 mm (24 in)
Feeder Length	914 mm (36 in) to 1,829 mm (72 in) centerline of inlet to centerline of discharge
Feed Rate	54.4 kg/hr to 22,680 kg/hr at 801 kg/m ³ (120 lb/hr to 50,000 lb/hr at 50 lb/ft ³) material
Belt Load	3.0 kg/m to 29.8 kg/m (2 lb/ft to 20 lb/ft)
Weigh Span	273 mm (10.75 in) typical
Belt	Endless polyester/monofilament carcass with FDA/USDA covers suitable for the application; Other belts available depending on application
Idlers	25.4 mm (1 in) diameter stainless steel with sealed bearings
Head Pulley	38.1 mm (1.5 in) diameter stainless steel with special chisel-shaped configuration
Speed Reducer	Motovario or equal shaft mount
Scale Weighbridge	Dual load cell, single-idler, pivotless full-floating weighbridge
Conveyor	Cantilevered frame and quick release take-up for easy belt removal; Stainless steel construction; Customer may specify belt removal on either the left or right side
Load Cell	Dual, low capacity bending beam transducers
Load Cell Excitation	10 V AC/DC recommended, 20 V AC/DC maximum
Nonlinearity	0.02% rated output
Repeatability	0.01% rated output
Hysteresis	0.02% rated output
Temperature Sensitivity	Zero: 0.0014% rated output/°C (0.0008% rated output/°F) Span: 0.0014% load/°C (0.0008% load/°F)

Digital Speed Sensor

Type	Digital, brushless
Mounting	Direct to shaft
Housing	Weather-tight

Options

- Top covers
- Side covers
- Bottom covers
- Variable speed drives
- Flow/no-flow switches
- Plugged chute switches
- Class 1 and 2 rated units
- High temperature belts
- Shut-off/maintenance gates



©2004 Thermo Electron Corporation. All rights reserved. Specifications, terms and pricing are subject to change. Not all products are available in all countries. Please consult your local sales representatives for details. Literature Code PI.8022.0104

Australia +1 61 (0) 8 8150 5300 +1 61 (0) 8 8234 5882 fax	Germany +49 (0) 208-824930 +49 (0) 208-852310 fax	South Africa +27 (0) 11-609-3101 +27 (0) 11-609-3120 fax	USA +1 (877) 290-7422 +1 (763) 783-2525 fax
Canada +1 (905) 888-8808 +1 (905) 888-8828 fax	Italy +39 02-959514-1 +39 02-953200-15 fax	Spain +34 01-657-3900 +34 91-661-5572 fax	
China +86 (0) 516-7793650 +86 (0) 516-7793652 fax	Netherlands +31 (0) 33-454-9000 +31 (0) 33-454-9009 fax	United Kingdom +44 (0) 1788-820300 +44 (0) 1788-820301 fax	

Process Instruments

www.thermo.com