



# OPERATING SPECIFICATIONS

## DM700/I

### LOOP POWERED INDICATOR

#### 1.0 DESCRIPTION

The DM700/I is a loop powered process indicator with a 4-digit red LED display. The DM700/I accepts a 4-20mA input signal and displays the associated process variable.

The instrument configuration settings are selectable via a simple to use menu system, which is navigated by the use of three push-button keys located on the rear of the display.

The entire assembly is sealed into a cap that fits directly onto the SCH4 series of connecting heads. Please refer to the datasheet for further information. ATEX versions are available for hazardous area use. Approval is pending.

#### 2.0 RECEIVING AND UNPACKING

Please inspect the packaging and instrument thoroughly for any signs of transit damage. If the instrument has been damaged, please notify your supplier immediately.

#### 3.0 SPECIFICATION @ 20°C

Input	4 to 20mA
Max Input Current	100 mA for 1 minute
Accuracy	±0.02% of full scale input
Max Display Range	-1999 to 9999
Stability	Zero 0.002%/°C Span 100 ppm/°C
Decimal Point	Programmable
Loop Drop	Less than 4 V @ 20mA
Display	4 digit 7.6mm red LED
Connection	Two way screw terminal block
Ambient Temperature	-20 to 75°C (Storage -50 to 85°C)
ATEX Approval	Optional and pending ATEX II etc.
EMC Approval	Tested to BS EN61326
Hart Transparent	Yes
Mechanical	Low profile SCH4 head ABS, IP67 rating when used with base unit

#### 4.0 INSTALLATION AND WIRING

- The maximum current rating for this device is 100mA for 1 minute. Exceeding this value will destroy the device. Fuse protection of the current loop to which this device is connected is highly recommended.
- This unit must only be series connected to a 4 to 20mA current loop. This device will be destroyed if connected directly across any supply with a current output greater than 100mA.
- Ensure the instrument is installed with adequate protection against the environment. IP67 rating must be maintained.
- Try to avoid installing the equipment close to sources of extreme temperature and electrical or electromagnetic interference.

##### 4.1 Configuration

Connect the device to a 4 to 20mA loop, set at any value between 4 and 20mA. To configure the device follow the simple configuration menus printed on the reverse side of this sheet. Fit the correct units legend to the front panel face.

##### 4.2 Enclosure

The SCH4 case offers various options for sensor/cable entry. Please refer to the SCH4 data sheet for further details.

All external cabling/sensor entries must maintain IP67 rating.



#### 4.3 Wiring and switch location (viewed looking at connector)

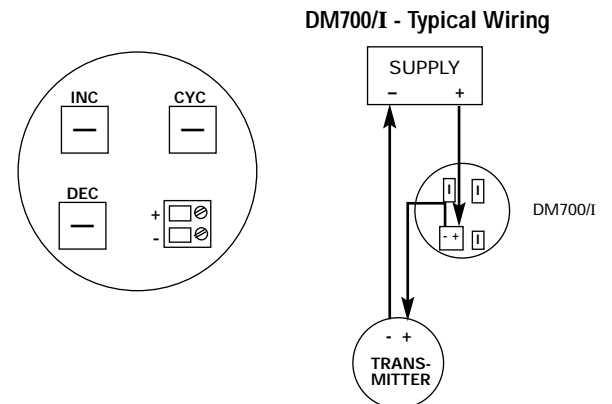

#### 5.0 MAINTENANCE

Apart from configuration this equipment requires no maintenance. If recalibration is required please contact your supplier for further information. Any cleaning of the instrument should be carried out using a mild detergent and a soft cloth. No solvents or abrasive cleaner should be used.

#### 6.0 MECHANICAL DETAIL

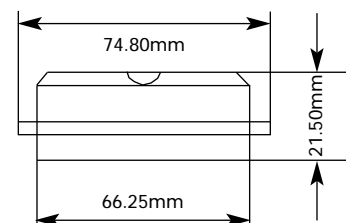

## 7.0 CONFIGURATION MENU

The prime function of the DM700/I device is to sink a 4-20mA current input and display the associated process variable (PV) in appropriate engineering units.

The section below describes the menus accessible on the DM700/I. By accessing these menus, the user can modify the instrument configuration in many ways. The following section refers to the configuration menu to describe how to configure the input scaling.

The instrument needs to know at least 2 co-ordinate pairs to define the relationship between mA input and display PV. The default method is to have SCAL (scaling) set to Stnd (standard). This allows the user to edit the ENLO (engineering low) and ENHI (engineering high) PV values that correspond to 4mA and 20mA input values, respectively. The default values for ENLO and ENHI are 0 & 100, respectively, giving a linear display range of 0-100 for 4-20mA input.

Alternatively, the user may not know the exact PV values at 4 & 20mA. You can choose AUTO scaling to solve this problem. This allows the user to edit ENLO and ENHI PV values that correspond to LO mA and HI mA input values, respectively. When the user accesses the SCAL (scale low) menu entry, the display flashes IPL0 (input low) to prompt the user to apply the LO mA value. Once the correct input signal is present and stable, the user should press ENT to store. The user is then prompted to apply the HI mA value (in SCHK/IPHI).

The user can choose Lin (linearization type) to NONE, 59rt, rt32, rt52 or USER.

- NONE is the default, and sets a straight linear relationship between mA input and PV. The input will go under/over-range at 3.8/21.5mA.

- 59rt (square root), rt32 (root 3/2) and rt52 (root 5/2) set a  $X^{1/2}$ ,  $X^{3/2}$  or  $X^{5/2}$  relationship, intended for flow applications where, for example, the flow is proportional to the square root of level. The input will go under/over-range at 3.8/21.5mA.
- USER allows user-defined linearization using up to 20 co-ordinate pairs. For example, if the user wanted to apply a 3-segment set of interpolated co-ordinate points as shown below, you would select Lin = USER, then set SEG5 = 3. The user would then set the mA interpolation points as IN1, IN2, IN3, IN4 = 5.1, 6.9, 12.3, 16.95. The corresponding PV interpolation points would be set as OUT1, OUT2, OUT3, OUT4 = 21.6, 32.5, 45.2, 75.1. The input would then go under/over-range at 5.1/16.95mA.

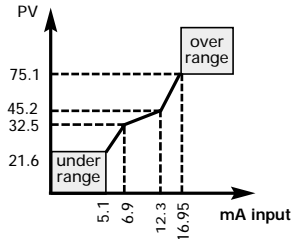

Once the input has been scaled using any of these methods, the user can choose to apply a constant offset to the PV, using the OFFSET setting. The user can also select the display resolution using the DEC setting. A menu access passcode can be set using the PRSS setting. The menu timeout period can be changed using the TOUT setting.

## 7.1 DM700 CONFIGURATION MENU GUIDE

There are three buttons, which the operator must press in various combinations in order to configure the device. These buttons are located on the underside of the indicator's circuit board. Viewed from the front, the three buttons (CYCLE, INCREMENT and DECREMENT) are shown in black and located as shown in the diagram to the left. Pressing 2 buttons simultaneously causes ENTER or ESCAPE actions.

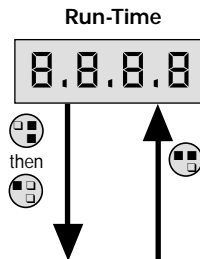
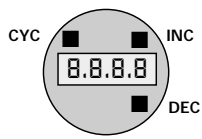

If no buttons are pressed for a minute or more, the device assumes run-time mode. The display shows the PV (if the input is in range) or shows --- or --- to indicate over/under range. In order to access menu configuration mode, the user must press ENTER followed immediately by CYCLE. In order to exit the menu and return to run-time, a user must press ESCAPE.

When cycling around menu, the title (e.g. Lin, SCAL etc.) is displayed for a second, then the menu entry is displayed ready for editing.



- INCREMENT menu entry
- DECREMENT menu entry
- ENTER to confirm entry, or:
- CYCLE to next menu entry
- ESCAPE

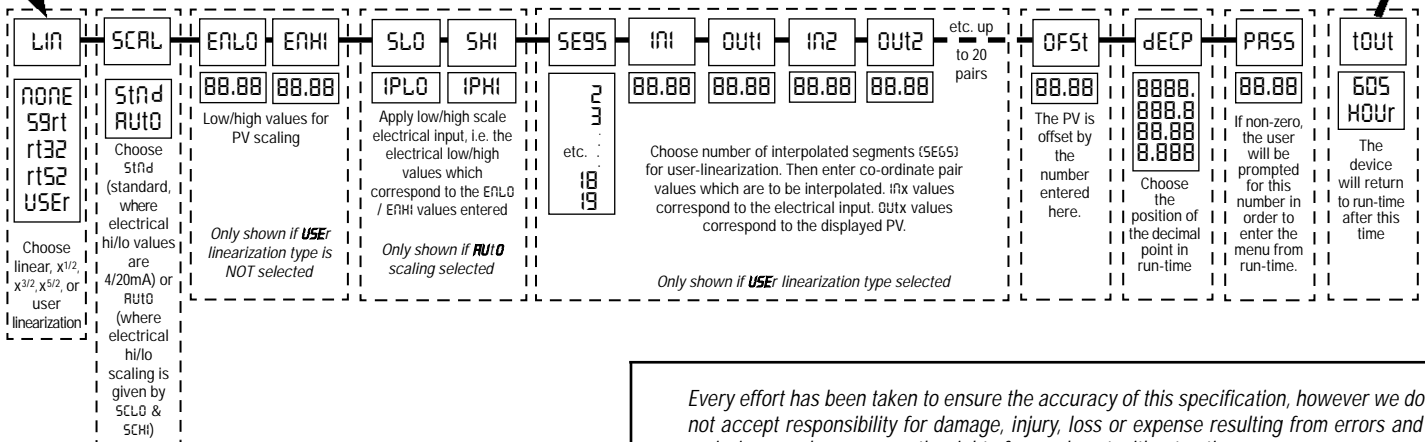

Every effort has been taken to ensure the accuracy of this specification, however we do not accept responsibility for damage, injury, loss or expense resulting from errors and omissions, and we reserve the right of amendment without notice.

**STATUS INSTRUMENTS INC.** [www.statinst.com](http://www.statinst.com)

PO Box 548, 456 Park Ave., Scotch Plains, NJ 07076 Ph: (908) 490-0232  
Ph: (800) 700-3272 Fax: (800) 700-5468 Email: rc@statinst.com