

DM540X

Intrinsically Safe

Digital

Thermometer

Designed, manufactured and supported by :

Status Instruments Ltd

Green Lane

Tewkesbury

Glos

GL20 8HE

Telephone : 01684 296818

Fax : 01684 293746

Every effort has been taken to ensure the accuracy of this specification, however we do not accept responsibility for damage, injury, loss or expense resulting from errors and omissions, and we reserve the right of amendment without notice.

Stock code : 52-314-2082-01

Issue :01

1.0 DESCRIPTION

The DM540X is an intrinsically safe battery powered indicator designed to be used in conjunction with a Pt100 temperature sensor. Temperature is indicated directly on the large LCD digital display in degrees Celcius or Fahrenheit, monitoring and updating maximum and minimum memories which may be displayed at any time on demand.

The instrument is fitted with a M16 process entry which can accept a wide range of integral or remotely mounted sensors. **(Subject to compliance with system certificate Ex94C2450).**

The unit incorporates stable high accuracy components and a microprocessor which continuously self calibrates, thus ensuring a high precision instrument which never needs calibrating during normal use.

2.0 RECEIVING AND UNPACKING.

Please inspect the packaging and instrument thoroughly for any signs of transit damage. If the instrument has been damaged, please notify your supplier immediately.

3.0 SPECIFICATION @ 20°C.

Ambient Temperature Range	0-40°C.
Measuring Range	-50.0 to 400.0 deg C or -58 to 600 deg F
Resolution	0.1 deg C or 1 deg F
Accuracy	+/- 0.1 deg C +/- 0.15 % reading + sensor errors or +/- 1 deg F + sensor errors
Stability	+/- 0.01 deg C / year.
Sensor	3 wire PT100 to BS1904 or DIN 43760 Sensor errors must be added to indicator errors to obtain overall measurement errors. Sensors with a choice of accuracies are available.
Lead effects	Insignificant for lead resistances < 10R per leg assuming all legs are equally matched.
Display	4 digit LCD with MAX, MIN, deg C, deg F and low battery legends.
Batteries	4 x MN1500 (AA). Approximate battery life @ 25 deg C ambient. 36 weeks - 1 second update rate. 1.5 years - 6 second update rate. 2.25 years - 12 second update rate.
Mechanical.	100mm diameter stainless steel housing with polycarbonate front membrane.
Warm up time	1.5 minutes

Intrinsic Safety Approvals

Apparatus EEx ia IIC T4
Cert. No. BAS Ex94C2449

System Cert. No. BAS Ex94C2450

EMC Compatibility

Complies with directive 89/336/EEC + 92/31 EEC

4.0 INSTALLATION AND WIRING.

4.1 INSTALLATION MUST BE CARRIED OUT IN ACCORDANCE WITH BS5345 - CODE OF PRACTICE FOR INSTALLATION OF ELECTRICAL EQUIPMENT IN HAZARDOUS AREAS.

4.2 For safe operation the battery cover MUST REMAIN IN PLACE whilst the apparatus is in a hazardous area.

4.3 General Recommendations

The instrument is a high accuracy digital thermometer. In order to ensure correct operation the following precautions should be observed:

- The instrument should be stored in a dry clean environment and remain in its original packaging prior to installation.
- The indicator should not be installed adjacent to electromagnetic starters, contactors, thyristor power units or electric switch gear.
- Any cleaning of the instrument should be carried out using a mild detergent and a soft cloth. No solvents or abrasive cleaners should be used.
- Any external cable entries or cables glands used in the installation should maintain the IP65 rating.
- Any installation should ensure that the instrument does not operate outside it's recommended operating limits. If in doubt, use a remote sensor.

4.4 Range Selection

The indicator can display either degrees Celcius or degrees Fahrenheit. Selection of the degrees Fahrenheit range is made by the fitting of link 1, see diagram below. The link is factory set in the "parked" position for degrees Celsius operation. The units are indicated on the display.

Fig 1 Connections & Links

LINK	OPERATION WHEN FITTED
1	°F
2	1 SEC MODE
3	N/A
4	TEST MODE
5	12 SEC MODE

LINK 1 IS SHOWN FITTED
LINK 4/5 SHOWN FACTORY SET IN PARKED POSITION

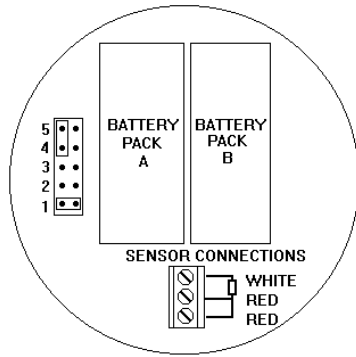

4.5 Battery Life

The standard battery life is typically 1.5 years at 25 deg. C ambient. The battery life may be extended by increasing the time between measurements from the standard 6 seconds to 12 seconds. This is achieved by fitting a link in position 5. When operated in the 12 second update mode, the battery life is extended to 2.25 years typically. Similarly the link may be fitted in position 2 for 1 second measurement interval

In 6 second update mode when there is approximately 1 month of battery life remaining, the low battery symbol will be displayed in the lower right corner of the LCD. After this period, the correct operation of the instrument cannot be guaranteed. If the instrument is configured in 12 second update mode, the low battery indicator will show when there is approximately 2 months of battery life remaining.

Please note that operating the instrument at ambient temperatures exceeding 25 deg C may result in reduced battery life.

4.6 Replacing The Batteries.

Carefully open the case by twisting the ring bezel anticlockwise and lift the front panel off. Unplug the sensor and remove the COMPLETE DISPLAY ASSEMBLY from the hazardous area (The battery cover must NOT be removed except in a SAFE AREA). Unscrew the three screws retaining the battery cover and remove the cover. Remove the four batteries from the battery holders and replace with new ones making sure to align the polarity markings on the batteries to those on the battery holder. Refit the battery cover and secure all three screws BEFORE returning the apparatus to the hazardous area. Plug in the sensor and reassemble the case ensuring that the gaskets are fitted and that the ring bezel is tight to ensure sufficient sealing. Check correct operation.

- Note : An incorrect reading may appear for the first 6/12 seconds.

4.7 Sensor Wiring.

The instrument will operate with optimum accuracy with a three wire sensor. A two wire sensor can be used but this may result in reduced accuracy. The sensor should be connected to the instrument via the three terminal connector mounted on the reverse of the printed circuit board as shown in figure 1.

Fig 2 DM540 Case Styles

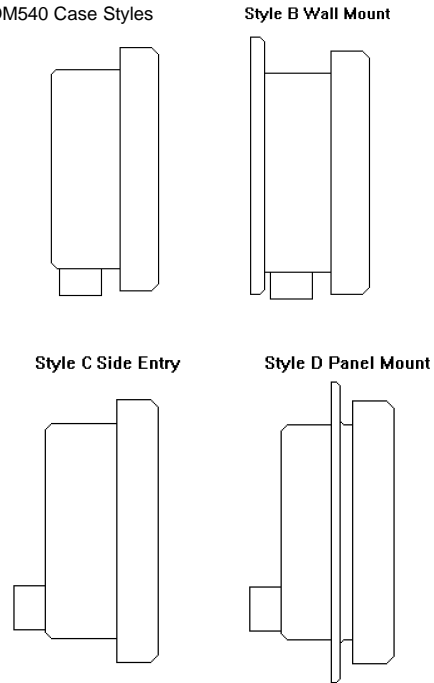

NOTE: Panel wall mount versions are retained through 3 hole Ø4.5 min equispaced on 115mm PCD.

Fig 3 DM540 Front Panel

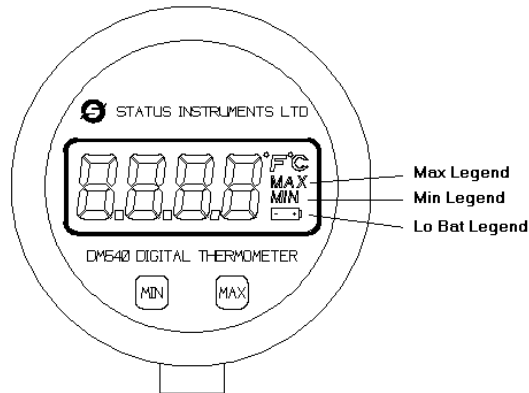

4.8 MAX / MIN Operation.

The digital thermometer stores the maximum and minimum temperatures which have occurred since its memories were last cleared. To view the required memory, press the respective button on the front panel. The required temperature and the appropriate legend will be displayed for a short time interval, depending upon the position of links 2 + 5 (see section 4.5) before returning to the current value.

To clear either memory hold both buttons simultaneously for three seconds. This causes both the **MAX** legend and the **MAX** value to flash, pressing the **MAX** button again at this point will reset the **MAX** memory. Alternatively pressing the **MIN** button will leave the **MAX** memory and cause the **MIN** legend and the **MIN** value to flash, pressing the **MIN** button again will reset the **MIN** memory. In short pressing the same button as the flashing legend resets that memory.

- Note : If no memory is cleared within 6 seconds, the instrument will time-out back to the current temperature display.

5.0 CALIBRATION.

Accurate measurement is achieved by comparing the resistance of the sensor to an accurate, stable, integral standard resistor. The unique design of the circuitry (patent applied for) means that any errors introduced by the measurement circuit are negligible, the net result being that there is no need to calibrate the instrument during its entire life.

If a calibration error is suspected, first check the probe and if correct, the instrument should be checked using a standard calibrated resistance box. If an error is found, the instrument should be returned to your supplier.

6.0 TROUBLESHOOTING.

A number of self checking and diagnostic routines are included in the instrument which assist fault finding in the event of error conditions occurring.

DISPLAY	POSSIBLE CAUSE	ACTION
No display	Batteries completely dead.	Replace batteries.
	System failure	Return to supplier.
Erratic display	Poor connections.	Check wiring.
	Excessive electrical noise.	Re-site instrument.
	Water ingress.	Clean, dry & re-fit glands. Check seals.
``- - -" displayed	Watchdog error - sensor open circuit or sensor short circuit. System failure.	Check wiring & sensor. Return to supplier.
"Lo" displayed	Sensor temp. less than -50 deg C (-58 deg F)	
"Hi" displayed	Sensor temp. greater than 399.9 deg C (600 deg F)	