



OPERATING SPECIFICATIONS SEM310 HART®

PROGRAMMABLE IN HEAD TEMPERATURE TRANSMITTER

1.0 DESCRIPTION

The SEM310 is a HART in head temperature transmitter that accepts any commonly used temperature sensor, slidewire transducer or millivolt signal and converts the output to the industry standard 4-20 mA transmission signal.

The software package RCP2 or a Hart Communicator with the necessary "Device Description" can be used to program the unit.

Separate instructions are available for programming the transmitter using RCP2.

2.0 SPECIFICATION @ 68°F

2.11 RTD Input (Pt100), 2 3 or 4 Wire

Sensor Range	-328 to +1562°F
Minimum Span ¹	50°F
Linearization	BS EN 60751 (IEC 751) BS 1904 (DIN 43760) JISC 1604 CUSTOM [X] ³
Max Lead Resistance	50 Ω per leg (balanced for 3 wire)
Basic Measurement Accuracy ²	±0.01% FRI ±0.07% Rdg (FRI = Full Range Input) 300µA to 500µA
RTD Excitation Current	300µA to 500µA
Thermal Drift	Zero 0.008 °F/°F, Span 400 ppm/°F

2.12 Thermocouple Input

Sensor Ranges	Thermocouple Type	Measuring Range* 4°F	Minimum Span ¹ °F
	TC Type K	-328 to 2450	90
	TC Type J	-328 to 2192	90
	TC Type T	-346 to 752	45
	TC Type R	14 to 3200	180
	TC Type S	14 to 3200	180
	TC Type E	-328 to 1832	90
	TC Type F(L)	-148 to 1112	45
	TC Type N	-292 to 2372	90
	TC Type [X] ³	±9999	Custom* ¹
Linearization	BS EN 60584-01 / BS 4937 / IEC 584-1 (Multi Segment Polynomials)		
Basic Measurement Accuracy ²	0.01% FRI* ⁴ ±0.07% rdg (Whichever is greater)		
Thermal Drift	Span 50ppm/°F		
Cold Junction Error	±1.00°F		
Cold Junction Tracking	0.05°F/°F		
Cold Junction Range	-40 to +185°F		

2.13 Millivolt Input

Input	Voltage Source
Range	-10 to +75 mV
Characterization	Linear Custom [X] ³
Minimum Span	5 mV
Basic Measurement Accuracy ²	±10µV ±0.07% Rdg
Input Impedance	10 M Ω
Thermal Drift	Zero 0.1µV/°C, Span 100ppm/°C

2.14 Slidewire Input

Input	3 Wire potentiometer
Resistance Range	10 Ω to 390 Ω (End to End) Larger values can be accommodated by external resistor, see Figure 2.
Characterization	Linear Custom [X] ³
Minimum Span ¹	5%
Basic Measurement Accuracy ²	0.1% FRI
Thermal Drift	Zero, 0.005% of span /°C Span, 100 ppm /°C
Range	0-100%

2.2 Output

Output Range	4-20 mA, Min. 3.8 mA, max. 20.2 mA
Accuracy	±5µA
Thermal Drift	1µA / °C
Supply Voltage ⁵	10 to 40V
Maximum Output Load	[(Vsupply - 10) . 21] K Ω 250 Ω minimum loop load for correct HART operation. ⁵



- Notes:**
1. Any span may be selected, full accuracy is only guaranteed for spans greater than the minimum recommended.
 2. Includes the effect of calibration, linearization and repeatability.
 3. Customer characterization is available pre-programmed at the factory. Contact your nearest Sales Office.
 4. Consult thermocouple reference tables for practical temperature ranges.
 5. For supply voltages over 30V, a minimum loop load of 500 Ω is necessary.

2.3 General

Input/Output Isolation	500V AC (breakdown voltage 3000V AC)
Time Constant (Filter Off)	0.5 secs (to 90% of final value)
Filter Factor Programmable	Off / selectable between 1 and 32 seconds / or Adaptive
Warm-up Tim	2 minutes to full accuracy
Re-calibration interval	1 year, to maintain accuracy to published specification. 5 years, to maintain accuracy to less than twice published specification.

Environmental

Ambient Operating Range	-40 to +185°F
Ambient Storage Temperature	-58 to +185°F
Ambient Humidity Range	10 to 95% RH non condensing

EMC

Emissions	EN50081-1
Immunity	EN50082-2

Mechanical

Enclosure	DIN standard terminal block size
Material	ABS
Weight	27g
Dimensions	1.69" [44mm] dia. x 0.83" [24mm] height
Flammability	US94-V0

2.4 Hazardous Area Certification

Note: In some installations, it may be possible to configure the transmitter in a hazardous area - for more details, contact the equipment supplier.

2.4.1 SEM310X Certification

FM3610
KEMA Ex-99.Y.4412X
EEx nA II T4...T6

Special conditions for safe use: The apparatus must only be connected to intrinsically safe circuits with the following maximum values: Umax - 30V; Imax - 100 mA; Pmax - 750mW

The apparatus must be housed in an enclosure which provides a degree of protection of IP20 for the terminals as per EN60529

2.4.2 Type "N" Applications

SEM310N

KEMA Ex-99.Y.4412X
EEx nA II T4...T6

Special conditions for safe use: The apparatus must only be connected to circuits with the following maximum values under normal operating conditions: $U_{max} - 30V$; $I_{max} - 100\text{ mA}$; $P_{max} - 750mW$

The apparatus must be housed in an enclosure which provides a degree of protection of IP54 for the terminals as per EN60529

3.0 INSTALLATION

3.1 Mechanical

The transmitter is mounted using spring loaded screws (supplied), on standard 33mm fixing centers and will fit a DIN standard termination head. The transmitter should be installed with adequate protection from moisture and corrosive atmospheres.

A $\varnothing 6.3\text{mm}$ hole is provided through the center of the transmitter to allow sensor wires to be threaded through the transmitter body direct to the input screw terminals. The screw terminals have been designed to allow all connection wires to enter from an inner or an outer direction.

Care must be taken when locating the transmitter to ensure the ambient temperature remains within the specified operating range.

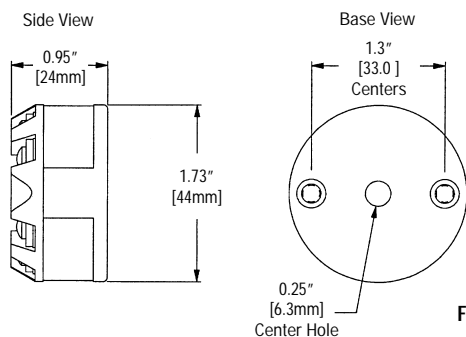

Figure 1

3.2 Electrical

Connections to the transmitter are made to the screw terminals provided on the top face. No special wires are required for the output connections, but screened twisted pair cable are the most suitable for long runs. It is recommended that screened cable is used for the sensor connection wires for cable runs greater than one meter. All input wires must have the same core diameter to maintain equal lead resistance in each wire.

Figure 2 shows the method of connection to provide a 4-20 mA current loop output. The output loop has a voltage power supply used to provide loop excitation. The load symbol represents other equipment in the loop, normally indicators, controllers or loggers. Care must be taken when designing the 4-20 mA circuit to ensure that the total voltage requirements of all the equipment in the loop added together, does not exceed the power supply voltage. If a number of instruments are connected in the loop, ensure that only one instrument is tied to ground. Grounding the loop at two points will cause a short circuit of part of the loop leading to measurement errors.

To guarantee CE compliance, sensor leads must be less than 3 meters long and the transmitter housing should prevent access to the transmitter during normal operation.

Figure 2

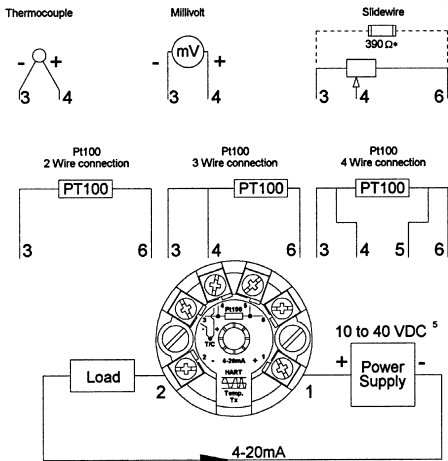

* Resistance Range, 10 Ω to 390 Ω (End to End)
Larger values can be accommodated by fitting 390 Ω resistor (not supplied) as shown.

4.0 HART PROGRAMMING

Consult HART website for more details: <http://www.hartcomm.org>

4.1 Connection Arrangement for HART Communicator

Figure 3.1a

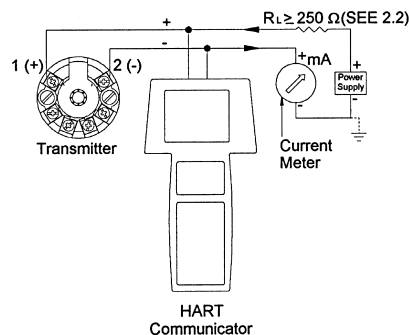
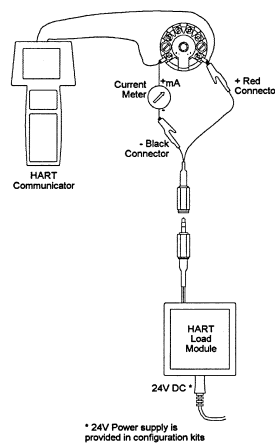

Figure 3.1b



4.2 Connection Arrangements for HART Modem (e.g. RCP2)

Figure 3.2.a

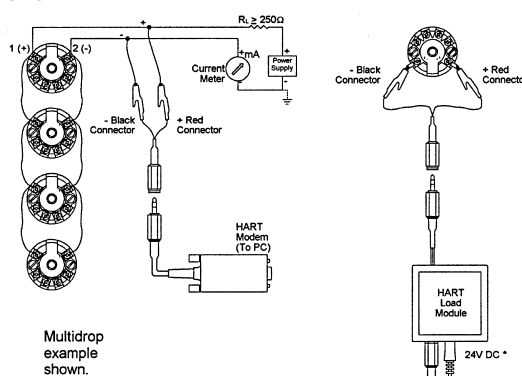
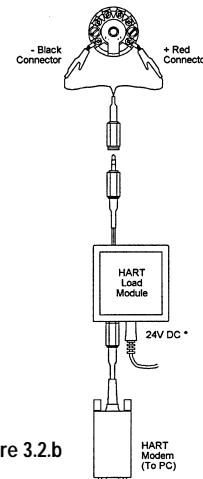

Figure 3.2.b



Note: Transmitters must be configured individually for Multidrop mode, by setting the Device Number between 1 and 15.

This cannot be done while the transmitters are connected together

The SEM310 can also be configured by connecting the Communicator or HART modem across the load in Figure 3.1a and 3.2a respectively

Every effort has been taken to ensure the accuracy of this specification, however we do not accept responsibility for damage, injury, loss or expense resulting from errors and omissions, and we reserve the right of amendment without notice.

STATUS INSTRUMENTS INC. www.statinst.com

PO Box 548, 456 Park Ave., Scotch Plains, NJ 07076 Ph: (908) 490-0232
Ph: (800) 700-3272 Fax: (800) 700-5468 Email: rc@statinst.com