



OPERATING SPECIFICATIONS

SEM1503/P & SEM1504/P

DIN RAIL MOUNTED Pt100 TRANSMITTER

1.0 DESCRIPTION

Temperature transmitters designed to accept a standard platinum resistance sensor (SEM1503/P; Pt100 2 or 3 wire. SEM1504/P; Pt100 2 or 4 wire) to BS EN 60751; 1996, DIN 43760 and convert the temperature to a 4-20 mA current loop. It is housed in a purpose designed DIN rail mount enclosure.

The transmitters are supplied to standard factory calibrated ranges, but can be user re-ranged to operate over most of the temperature ranges encountered in industrial and building management applications. The enclosure provides trim potentiometer access, allowing fine re-calibration adjustments to be made at both ends of the scale. thermocouple selector.

2.0 SPECIFICATION @ 20°C

2.1 SEM1503/P & SEM1504/P

INPUT

Type	Pt100 2 or 3 wire (SEM1503/P) Pt100 2 or 4 wire (SEM1504/P)
Accuracy	Accuracy $\pm 0.15^\circ\text{C} \pm \% \text{ reading}$ as follows: 500°C to 600°C 0.4% rdg 200°C to 560°C 0.2% rdg 0°C to 200°C 0.1% rdg 0°C to -100°C 0.2% rdg -100°C to -180°C 0.4% rdg
Range Select	Coarse Settings by side entry 16 position rotary screw adjustment switches. Fine setting by front access pots.
Ranges	(4 mA Reading) (4-20 mA Range)
Excitation	2 mA nominal SEM1503P 1 mA nominal SEM1504P

OUTPUT

Type	Passive 2 wire current output
Range	4 to 20 mA (30 mA max)
Protection	Reverse connection plus over voltage
Voltage	10 - 30V DC
Thermal Stability	Typical 100ppm/°C overall
Ripple	Less than 40µA/V (Measured at 1V ripple 50 Hz)
Response	100 mS to reach 70% of final value
Max Load	700R @ 24V

2.2 General Specifications

Ambient	0-50°C; 10-95% RH Non condensing
Connection	Captive clamp screws
Cable Size	4 mm sq solid / 2.5mm sq stranded
Case Material	Grey Polyamide
Flammability	To UL94-VO VDE 0304 Part 3, level IIIA
Protection	IP20
Dimensions	60 x 75 x 12.5mm, 45 grams
Mounting	Snap on top hat (DIN EN 50022-35)
Compliant With	EN50081-1, EN50082-1

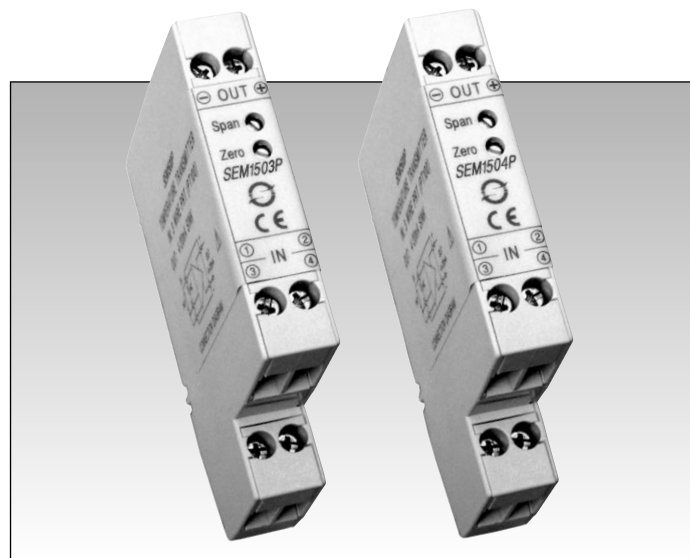

3.0 INSTALLATION

3.1 Mechanical

This transmitter must be housed within a suitable enclosure that will provide protection from the external environment, ensuring that the stated temperature and humidity operating ranges are not exceeded. It is good practice to mount the transmitter away from sources of electrical noise, such as switchgear and transformers. The transmitter enclosure is designed to snap fit onto a standard "TOP HAT" DIN rail. To remove from rail, apply pressure at the bottom face at the back upwards towards the rail to release the spring clip and tip away from the top. The transmitter may be mounted in any orientation and stacked side by side along the rail.

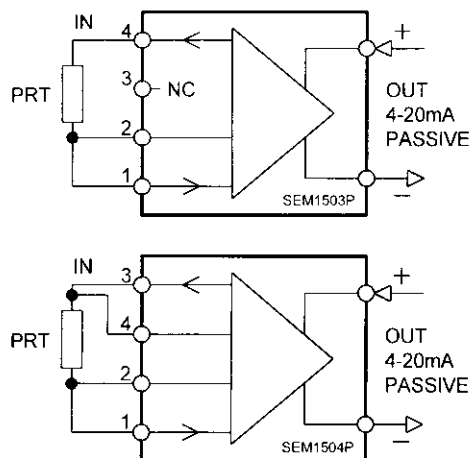

3.2 Electrical

Connection to the transmitter are made via screw terminals, with wire protection plates provided on each terminal. To maintain CE compliance twisted pair (screened) cables should be used for the signal connections with screens grounded at one end only.

SEM1053/P The sensor is connected with two or three wires, the third is used to compensate for cable resistance, all three wires must be of the same size and type in order for this compensation to work correctly. Incorrect sensor connection or sensor wire break will result in the output current saturating either up or down scale. It is good practice to ensure all 4-20 mA signal loops are grounded at one point.

SEM1054/P The sensor is connected with two or four wires. Incorrect sensor connection or sensor wire break will result in the output current saturating up scale. It is good practice to ensure all 4-20 mA signal loops are grounded at one point.

Care must be taken when designing a 4-20 mA circuit to ensure that the total burden of the loop, (that is the total voltage requirement of all the equipment connected in the loop at 20 mA) does not exceed the power supply voltage.

To operate correctly the transmitter requires a minimum of 10 volts across its output terminals. The transmitter is protected against reverse connection and over voltage. Figure 1 shows a typical 4-20 mA circuit, the load resistor represents equipment such as indicators, loggers, PLC, etc.

Figure 1

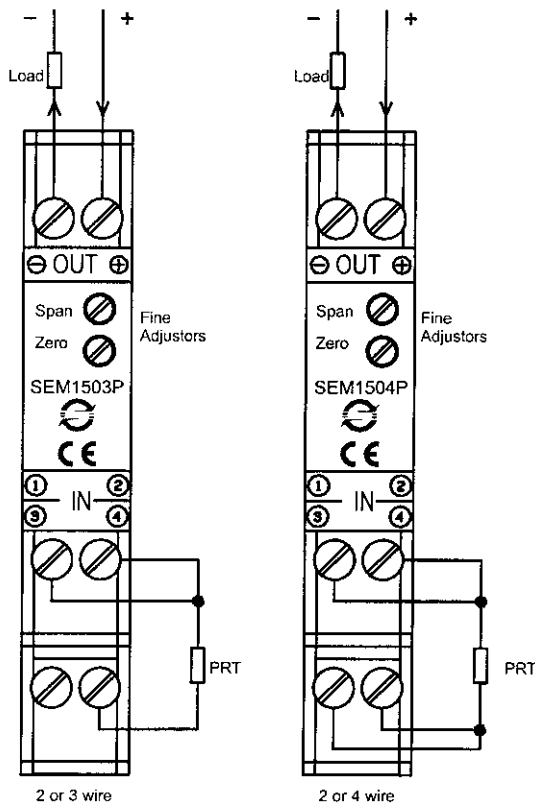

4.0 RANGE SETTING AND CALIBRATION

The following equipment is required:

- Precision resistors or resistance decade box to simulate Pt100
- DC milliamp meter (digital); accuracy 0.05% on 0 to 20 mA range
- Power Supply; 24V DC 30 mA Min
- Trim tool and Pt100 resistance tables.

Decide on the range you require and ensure the transmitter is capable of this range. If a range was not specified at time of order, the transmitter will leave the factory set as 0 to 100°C.

1. Connect Resistance box to input terminals. Ensure 3 identical wires are used on the SEM1503P, 4 identical wires used on the SEM1504P. Connect + Signal Terminal to + power supply terminal. Connect mA meter in series with the return wire from the - Signal terminal to - terminal on power supply. Turn on. Allow a few minutes before calibration for the transmitter to stabilize after handling.

Let T_1 = Temperature at 4 mA output
 T_h = Temperature at 20 mA output

2. Set resistance box to simulate T_1 , first rotate coarse offset to obtain a output reading close to 4 mA. Use fine zero adjuster to trim reading to 4 mA \pm 0.005 mA. (If fine trim hits end of travel re-adjust coarse adjuster one step re-adjust fine offset).
3. Set resistance box to simulate T_h , first rotate coarse gain to obtain a output reading close to 20 mA. Use fine span adjuster to trim reading to 20 mA \pm 0.005 mA. (If fine trim hits end of travel re-adjust coarse adjuster one step re-adjust fine span. Note clockwise rotation of the coarse adjuster reduces output current).
4. Set resistance box to T_1 , adjust fine offset for 4.00 mA \pm 0.005 mA.
5. Set resistance box for T_h , adjust fine span for 20.000 mA \pm 0.005 mA.
6. Repeat steps 4, 5 until both points are in calibration
7. Turn off power and remove wires. Mark transmitter with the new range.

5.0 MECHANICAL DETAIL

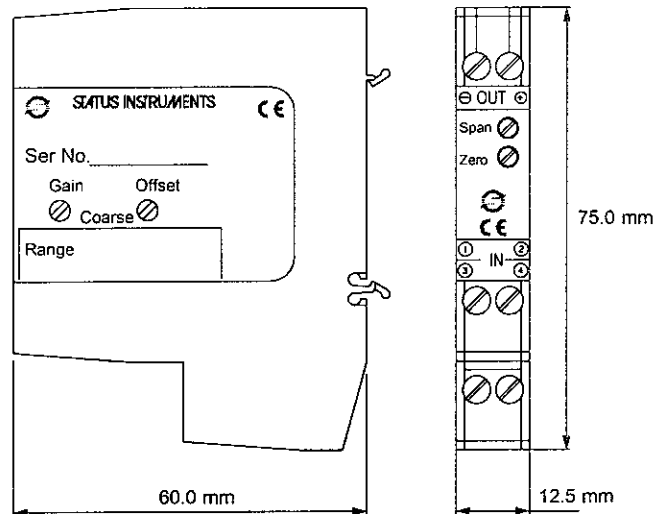

Every effort has been taken to ensure the accuracy of this specification, however we do not accept responsibility for damage, injury, loss or expense resulting from errors and omissions, and we reserve the right of amendment without notice.

STATUS INSTRUMENTS INC. www.statinst.com

PO Box 548, 456 Park Ave., Scotch Plains, NJ 07076 Ph: (908) 490-0232
 Ph: (800) 700-3272 Fax: (800) 700-5468 Email: rc@statinst.com