



# OPERATING SPECIFICATIONS SEM1300

## POWER SUPPLY UNIT

### 1.0 DESCRIPTION

The SEM1300 is a DIN rail mounted power supply that provided a regulated 24V DC output @ 250 mA from an AC supply ranging from 90 to 253V AC 50/60 Hz.

The SEM1300 is ideally suited for powering 24V process instrumentation and signal conditioning modules. Its small size allows for a compact installation.

The high efficiency of the SEM1300 power supply and its very cool running operation ensures a lower ambient temperature rise and hence improved reliability.

### 2.0 SPECIFICATION @ 20°C

#### 2.1 SEM1300

##### INPUT

SUPPLY	90 - 253V AC 50/60 Hz
EFFICIENCY	70% TYP AT 230V AC 250 MA
PROTECTION	1 A (T) anti-surge fuse (not supplied, must be fitted in the live supply line)
FILTER	Inbuilt EMC filter
POWER RATING	10 VA maximum

##### OUTPUT

VOLTAGE	24V DC $\pm 0.5\%$ @ 250 mA - Short circuit protected
RIPPLE	100mV peak to peak
INDICATION	Power on LED
ISOLATION	2500 V Flash tested to supply
EMC TESTED TO	IEC 801-2 Susceptibility to E.S.D. IEC 801-3 Radiated Susceptibility IEC 801-4 Susceptibility to conducted interference EN 55022 Class B Radiated Emissions BS EN 61010-1
ELECT. SAFETY	

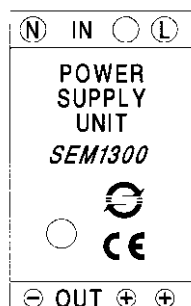
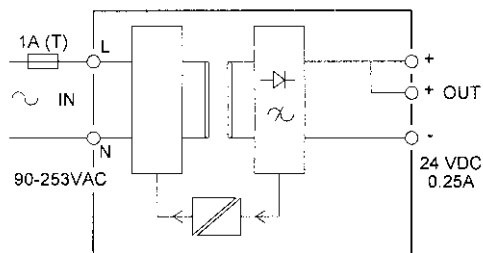

### 2.2 General Specifications

AMBIENT	0 - 50°C; 10-95% RH non condensing
PROTECTION	IP20
CONNECTION	Captive screw terminals
CABLE SIZE	4mm sq solid / 2.5mm sq. stranded
CASE MATERIAL	Grey Polyamide
FLAMMABILITY	To UL94-V0 VDE 0304 Part 3, Level IIIA
DIMENSIONS	60 x 60 x 21mm (67.5mm above Rail)
MOUNTING	Snap on top hat (DIN EN 50022-35)
MAX VIBRATION	12G 10 to 55 Hz at double amplitude 2mm
SHOCK RES	12G
WEIGHT	100 grams

### 3.0 INSTALLATION

This power supply must be housed within a suitable enclosure that will provide protection from the external environment, ensuring that the specified operating temperature and humidity ranges are maintained.

The SEM1300 case is designed to snap fit onto a standard "TOP HAT" DIN rail. To remove, apply pressure on the bottom back of the enclosure, push upwards towards the rail to release the spring clip and tip forward. The unit may be mounted in any orientation and stacked side by side along the rail, but SEM1300 is best located clear of any signal wires or equipment.

#### 3.1 Mechanical

##### WARNING



- If not installed and used in accordance with these instructions, protection against hazards may be impaired.
- Hazardous voltages may be present on the terminals - the equipment must be installed by suitably qualified personnel and mounted in an enclosure providing protection to at least IP20.

Connections to the unit are made via screw terminals. Wire protector plates are provided inside each terminal. **IMPORTANT - a 1 A (T) anti-surge fuse must be connected in series with the live supply line and a suitable switch or circuit breaker, which should be near the equipment.** Two positive output terminals are provided to ease wiring.

The equipment contains no user serviceable parts.

Installation overvoltage category - 2 (as per BS EN61010-1)

If this equipment is to be used in environments with overvoltage category 3, transient suppressors should be installed on supply wiring.

### 4.0 MECHANICAL DETAIL

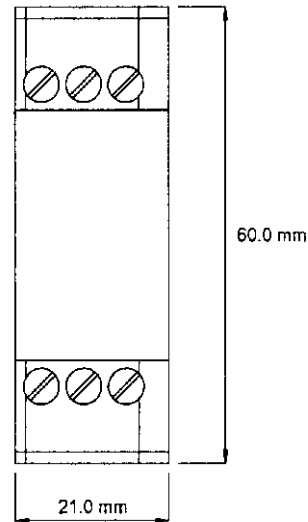
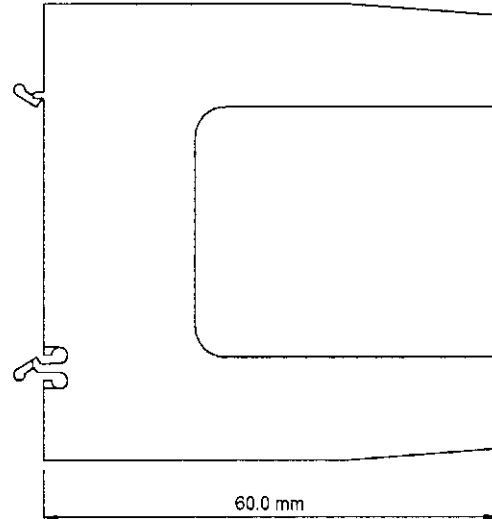

*Every effort has been taken to ensure the accuracy of this specification, however we do not accept responsibility for damage, injury, loss or expense resulting from errors and omissions, and we reserve the right of amendment without notice.*

**STATUS INSTRUMENTS INC.** [www.statinst.com](http://www.statinst.com)

PO Box 548, 456 Park Ave., Scotch Plains, NJ 07076 Ph: (908) 490-0232  
Ph: (800) 700-3272 Fax: (800) 700-5468 Email: [rc@statinst.com](mailto:rc@statinst.com)